

Welcome to AustraliaCDRhelp.Com

CAREER EPISODE - I

Design of In-Pipe Reliable Leakage Detector

A) Introduction

[CE 1.1]

Project: Design of In-Pipe Reliable Leakage Detector

Duration: [Date] – [Date]

Location: Deakin University, Australia

Position: Electrical Engineering Student

B) Background

[CE 1.2] A fairly sizable water amount is lost due to pipes faults and leakages in most water distribution systems. Due to this reason, the leaks individuation is adequate for water resources optimization and rationalization. Thus, the methodologies and techniques which are presently utilized for the leaks individuation, despite the fact considering universally accepted phenomena based on techniques which are accepted currently. These are time-consuming and main need highly experienced personnel. Furthermore, the methods become ineffective and unreliable when conducting measurements in the pipe's specified operational conditions. Thus, the working was done on a wireless sensor network for detecting and locating the issue.

[CE 1.3] The project aim consisted of two units that were placed in a specific difference. I worked on setting the sensor output which kept the same when considering the fact that there was no leakage. In case if there was any difference, it resulted in pipeline leakage and it sent to PC from ZIGBEE which was followed with closing the source valve with DC motor assistance. I controlled the motor with the assistance of the relay.

[CE 1.4] The work activities were predefined in the project and various scenarios were analyzed¹

Name: PROFESSIONAL CIVIL ENGINEER - QUANTITY SURVEYOR



AustraliaCDRHelp.Com
Competency Report Writing Helper

mainly for getting the targeted work results and achieving the specified results within the defined work tenure. I accomplished all the related project duties under the assistance of the project guide.

[CE 1.5]

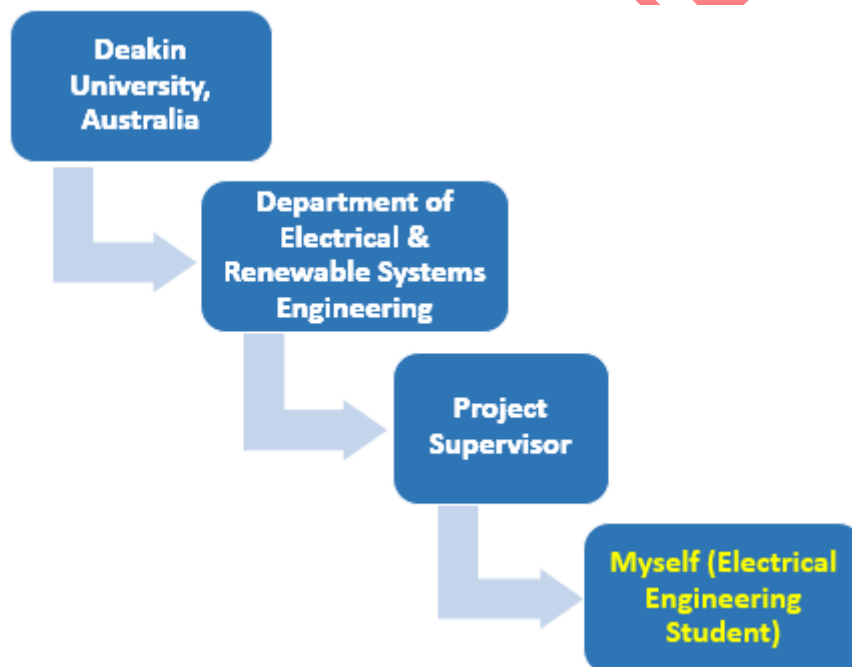

[CE 1.6] Responsibilities:

- I applied Electrical Engineering expertise for water flow from the flow sensor and output attained from the amplifier to the microcontroller.
- I executed the signal conditioning unit which assisted well in accepting input signals from the analog sensors.
- I did a microcontroller transmitter pin connection in the circuit mainly connected for converting 5V input to RS232 level.
- I utilized a diode rectifier which assisted in providing full-wave rectified voltage mainly resulted in filtering from a simple capacitor filter for dc voltage production.

2

Name: PROFESSIONAL CIVIL ENGINEER - QUANTITY SURVEYOR



C) Personal Engineering Activity

[CE 1.7] I designed the project which consisted of the amplifier, flow sensor, Zigbee, microcontroller, motor, and driver circuit. I monitored the water flow from the flow sensor and output was provided to the microcontroller from the amplifier. I utilized the microcontroller for transmitting the information to the PC from ZIGBEE. I utilized RS232 serial communication cable for microcontroller interfacing with ZIGBEE. There were two units considered in the work mainly based on a specified difference and if both sensors output were the same, the consideration was made that there was no leakage. I made pipeline leakage consideration if there was any difference and sent it to PC from ZIGBEE. I closed the source valve with DC motor utilization. I did motor controlling with the assistance of the relay. I implemented the signal conditioning unit which accepted input signals from the analog sensors and obtained 5V DC conditioned output mainly corresponded to each parameter set range. I utilized the unit for accepting the digital sensor inputs and obtained 10-bit binary outputs with +5V positive logic level. I generated the calibration voltages and the health bits in the unit and microcontroller were widely utilized for controlling operation. I worked on obtaining real-time control from processing analog signals obtained from the system. I executed the suitable isolation surface which required to be designed for interaction among the high voltage hardware and the control circuit.

[CE 1.8] I implemented the signal conditioning which provided mandatory interface among low voltage controller unit and high power grid inverter. I used MAX 232 IC as a level logic controller and MAX232 worked with capacitive voltage generator for supplying 232 voltage levels from 5V supply. I utilized the receiver for converting EIA-232 to 5V CMOS levels and each driver converted CMOS input levels to set 232 levels. I connected the microcontroller transmitter pin in the circuit which was connected with converter for converting 5V input to RS232 level. I connected the T2OUT pin to the receiver pin which worked as D type serial connector directly connected to PC. I sent the transmitting data to MAX232 through the transmitting pin which converted the RS232 level to set 5V level. I connected the R2OUT pin to the microcontroller receiver pin. I transmitted and received the data among PC and microcontroller.

[CE 1.9] I used the potential transformer which resulted in stepping down the power supply voltage from 0V ac to 15V dc. I connected the potential transformer secondary to the precision rectifier which was constructed with the operational amplifier assistance. I utilized the precision rectifier which provided peak voltage output as DC and gave RMS output. I analyzed the bridge rectifier when four diodes were connected and the circuit was termed as a bridge rectifier. I applied the circuit's input to the opposite network corners and the output was taken from the circuit. I analyzed the bridge rectifier benefit over conventional full-wave rectifier with the transformer for bridging rectifier and it produced a voltage output which was twice that of the conventional full-wave circuit. This showed by assigning values of the components and assuming that the transformer was utilized in both circuits. I developed peak voltage among points X and Y which was 1000 volts in both circuits. The peak voltage was based on center tap to either X or Y and it was set to 500 volts. There was one diode conducted at any instant and the maximum voltage rectified at any instant was 500 volts.

3

Name: PROFESSIONAL CIVIL ENGINEER - QUANTITY SURVEYOR



AustraliaCDRHelp.Com
Competency Report Writing Helper

[CE 1.10] implemented the transceiver block diagram which is underneath:

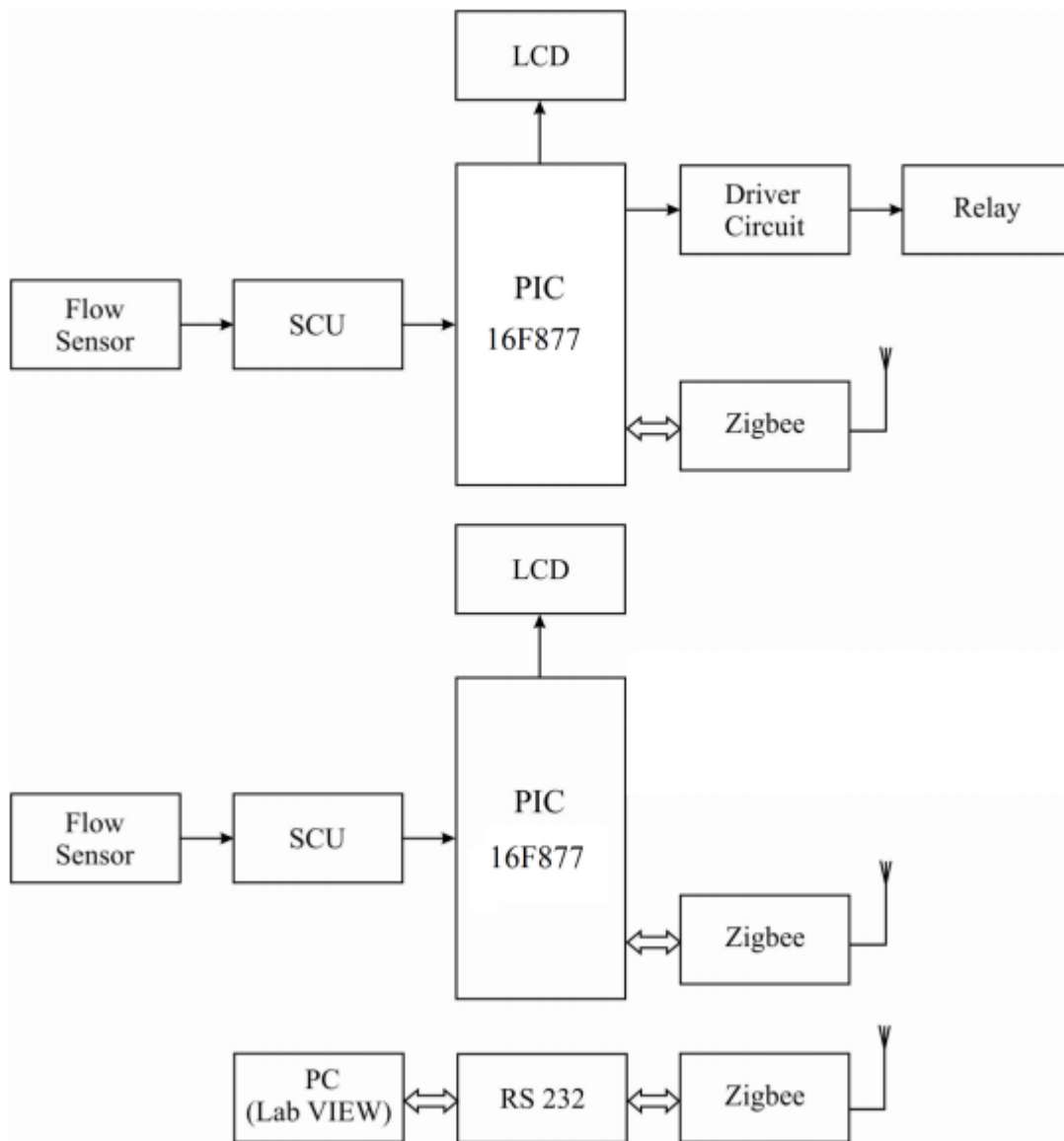

I applied AC voltage which was based on 220Vrms and it was connected to the transformer. It resulted in stepping AC voltage down to the desired dc output level. I used a diode rectifier which provided a full-wave rectified voltage and it was initially filtered from a simple capacitor filter for producing a dc voltage. This resulted in dc voltage mainly based on ac voltage variation.



The voltage regulators mainly comprised of ICs and it contained the circuitry for comparator amplifier, reference source, overload protection, and control device in a single IC. I specified the IC unit which provided regulation of either a fixed positive voltage, adjustable set voltage, or a fixed negative voltage. There was a fixed three-terminal voltage regulator and it provided⁴

Name: PROFESSIONAL CIVIL ENGINEER - QUANTITY SURVEYOR

unregulated dc input voltage. I implemented one input terminal, the voltage from a second terminal, and a regulated dc output voltage with ground connection to the third terminal.

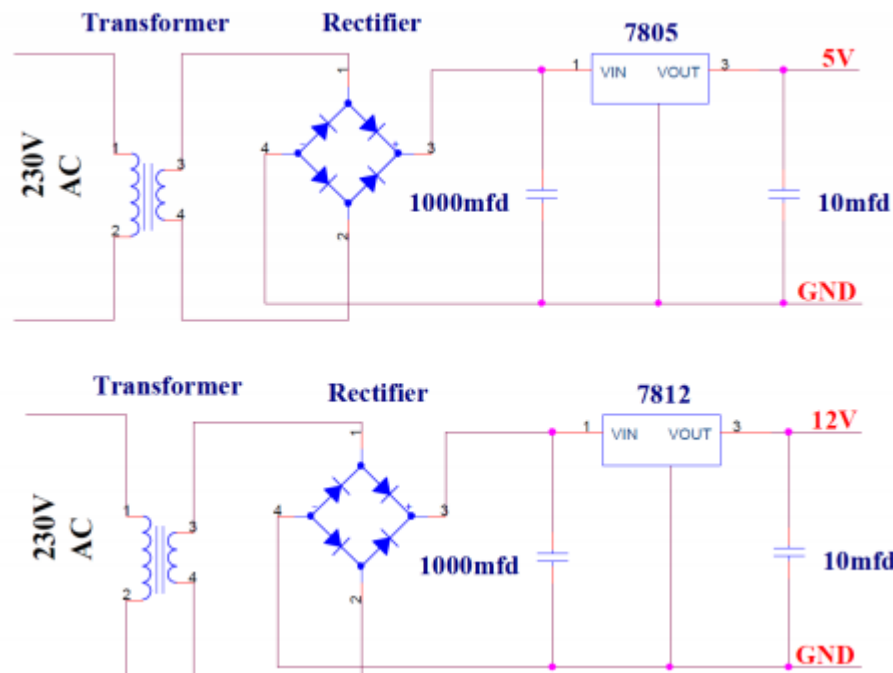

I utilized the regulators for providing fixed positive regulated voltages from 5 to 24 volts. Also, the series regulators provided fixed negative regulated voltages.

[CE 1.11] I utilized the PIC which started with the development system from microchip technology and it provided product development with low cost highly flexible microcontroller design toolset for PIC microdevices. I initiated the PIC for carrying out the system development and MPLAB IDE was executed for system implementation. I executed the PIC which provided the program with the ability for programming user software and it was in relation to the microcontrollers. I initialized the PIC software under MPLAB which provided full interactive control over the programmer.

D) Summary

[CE 1.12] I proposed the system dependent on PIC microcontroller which was compact, less complex, and user friendly. It was readily based on utilizing for performing the defined tasks. There were numerous tedious and repetitive projects. I did the design based on meeting the industrial requirement and extending it for other purposes like research and commercial applications. Because of the high technology probability utilized, the control was based on smart urban water distribution monitoring and controlling with fewer hardware circuits. I executed the system for obtaining the required results and achieved the desired objectives with electrical engineering skills usage.

Career Episode 2

Multi-way Relay Networks

A) Introduction

[CE 2.1]

Title: Multi-way Relay Networks

Duration: [Date] – [Date]

Location: Deakin University, Australia

Position: Electrical Engineering Student

B) Background

[CE 2.2] Multiple users mainly work for data transmission via relay at the same time in multi-way relay networks. The relay mainly communicates in a bi-directional manner among different users in the pairwise transmission. There is the SNR (signal to noise ratio) penalty without the proper synchronization.

[CE 2.3] The project scope was carrying out error performance investigation in the data transmission among users in the symbol misalignment and phase offset presence. I applied the knowledge for designing appropriate algorithms for improving the performance and investigated the error in the multi-way network. It was of higher significance in data transmission when carrying out performance improvement and error reduction. The appropriate research was made in the entire project tenure specifically for obtaining the targeted project results.

[CE 2.4] The work nature was carrying out an error performance investigation of a multi-way relay network among the user's signal when there was phase offset. I did an error performance investigation of a multi-relay network when there was a user's signal symbol misalignment.



[CE 2.5]

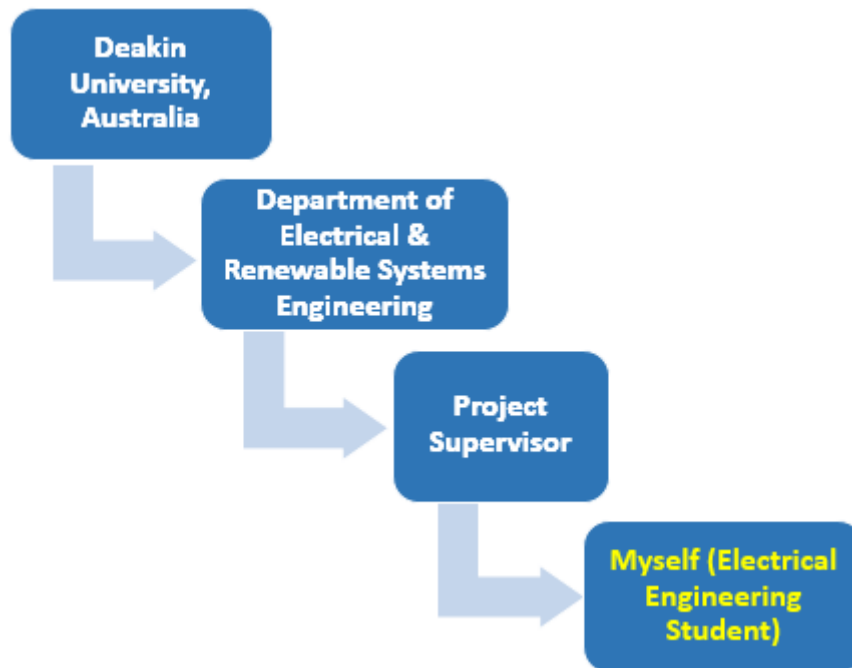

[CE 2.6] My technical responsibilities were:

- I initialized the work activities with phase offset values variations and mainly noted the considered case results.
- I did signal decoding at the user end which resulted in implementing the maximum likelihood criterion.
- I worked on researching the utilization of the user's signal mainly for extraction of the message with own signal subtraction.
- I worked on plotting the graph with a specified probability function which was linked with one error against the SNR ratio mainly accomplished using engineering skills.

C) Personal Engineering Activity

[CE 2.7] I conducted the research based on the occurrence of pairwise transmission and observations mainly based on noting the probability of at least a single error when there was no symbol misalignment and phase offset in the normal pairwise transmission. It indicated the lower probability mainly resulted in getting error and another step was based on the phase offset which adequately applied for investigation of system error performance in the user signals. I obtained variations in the phase offset values and noted in the under-considered cases. It indicated a higher probability of obtaining at least one error. Also, I applied the misalignment and the change impact was considered in the symbol misalignments. I plotted the graphs and observed the results which showed the error higher probability. It indicated that there was no proper synchronization in the user signals and the error

Name: PROFESSIONAL CIVIL ENGINEER - QUANTITY SURVEYOR

rate in the system was also higher.

[CE 2.8]I implemented the project methodology in which the system model was executed and it consisted of broadcast phase and multiple access. The project methodology is below:

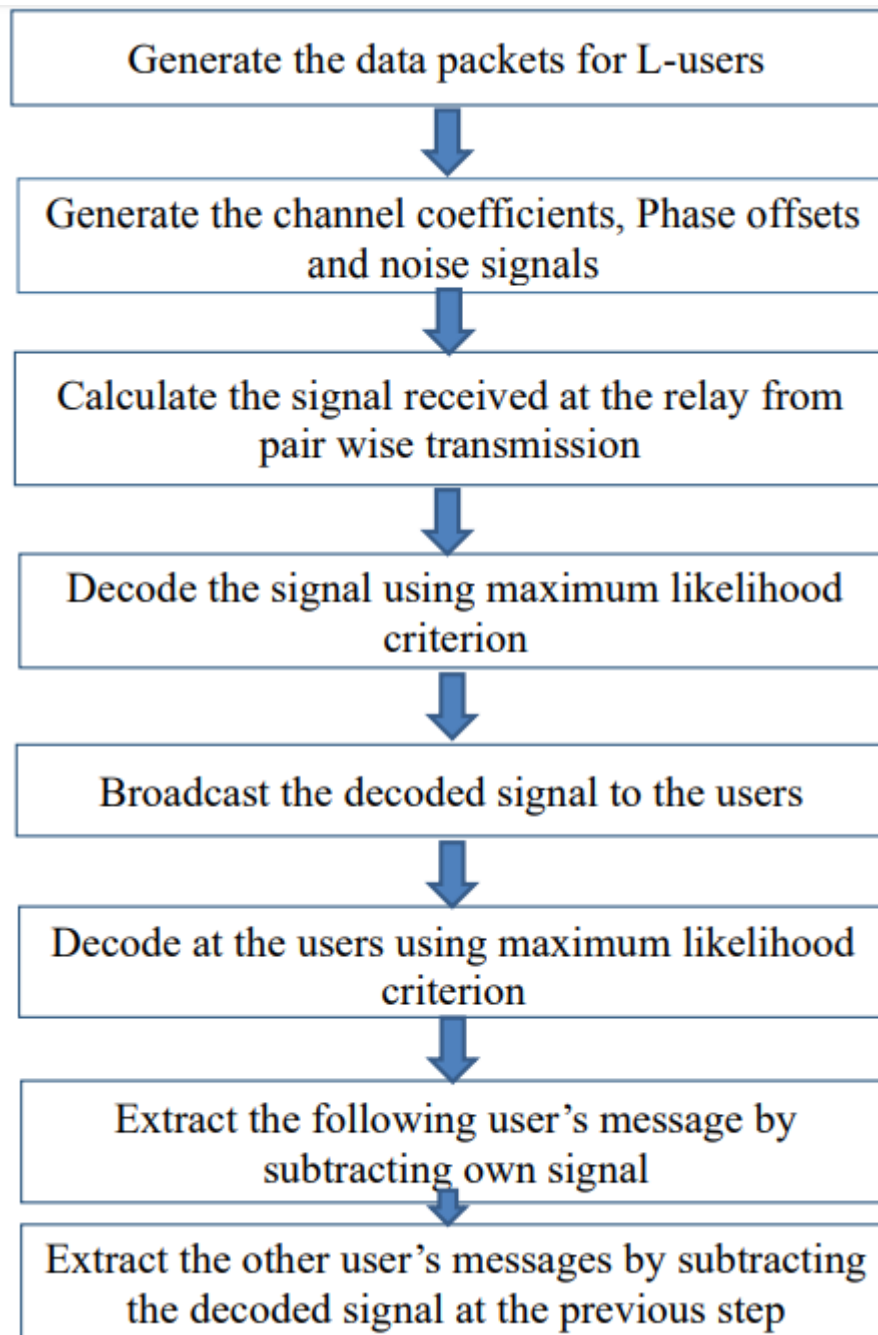

I executed the flowchart as shown above and it indicated the detailed methodology from which the project was gone towards completion. I generated data packets for the L-users with the noise signals and channel coefficients. I received the signal at the relay from the users' pairwise transmission which was calculated and the signal decoded utilizing the maximum likelihood criterion. It resulted in providing maximum possible chances and the decoded signal from the relay mainly broadcasted to allg

Name: PROFESSIONAL CIVIL ENGINEER - QUANTITY SURVEYOR



the users. I decoded the signal at the user end from utilizing the method based on the maximum likelihood criterion. I made sure that the user utilized its signal for the user's message extraction with subtracting the own signal. I carried out the subtraction of the user's message with the decoded signal at the previous step. It resulted in providing normal pairwise transmission and the normal transmission error probability was noted against the probability plotting graph with at least one error against the signal to noise ratio (SNR). It resulted in giving a clear view of the system error performance when there was no symbol misalignment and no phase offset. In the second stage, I applied the phase offset in the pairwise transmission and it led towards transmission's time delay. It was usually in pairwise transmission when the user sent data at the same time. I provided phase offset for noting the change in the probability change error. The graph was plotted with the phase offset on probability with at least one error against SNR. I observed the results with numerous phase offsets and the symbol misalignment was applied in the transmission of normal pairwise type. Because of the symbol misalignment, there was a difference noted at the relay's received signal. I plotted the graph which resulted in indicating one error against the signal to noise ratio (SNR).

[CE 2.9]I generated the graphs which indicated the error probability with the change in the phase offset with respect to the SNR. I noted the clear variations from the graph and the change was provided with the phi value which worked with the applied phase offset in the system. I obtained the results which showed one error probability where $p > 0$ and it worked when there was no symbol misalignment and no phase offset. It mainly termed as normal transmission.

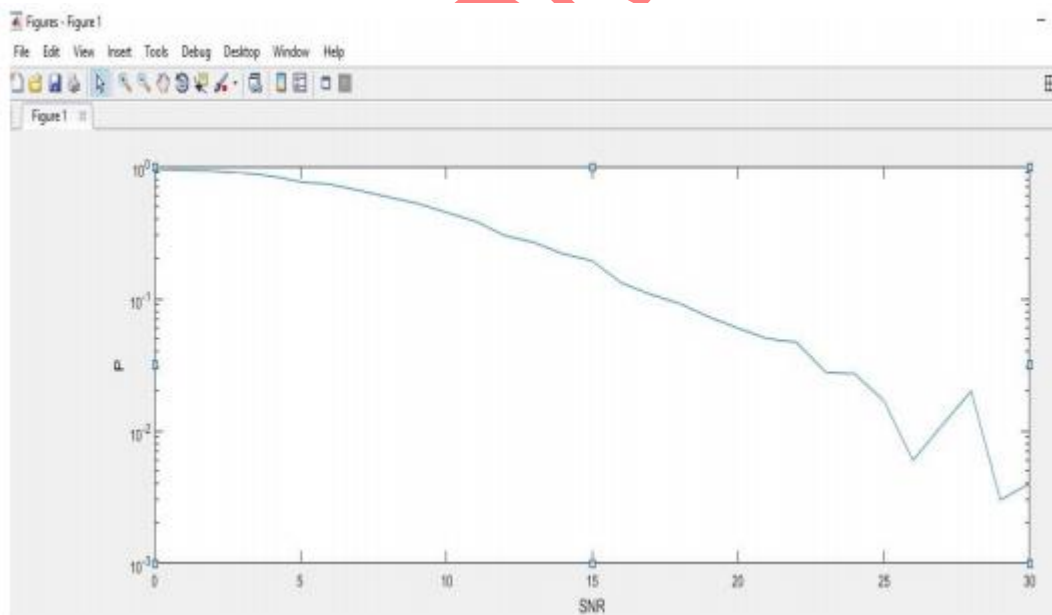

I obtained the probability error in first observation which led towards providing an error where there was no phase offset. It indicated that the probability obtained was low and provided the probability for the normal pairwise transmission in the multi-way relay network.

[CE 2.10] In another observation, I showed the cases which worked with different ϕ values and it worked with applying the phase offset values in the user signal. I plotted with the graph with probability supported for at least one error against the signal to noise ratio (SNR). It resulted in showing that the probability of at least one error was higher when there was phase offset in the system.

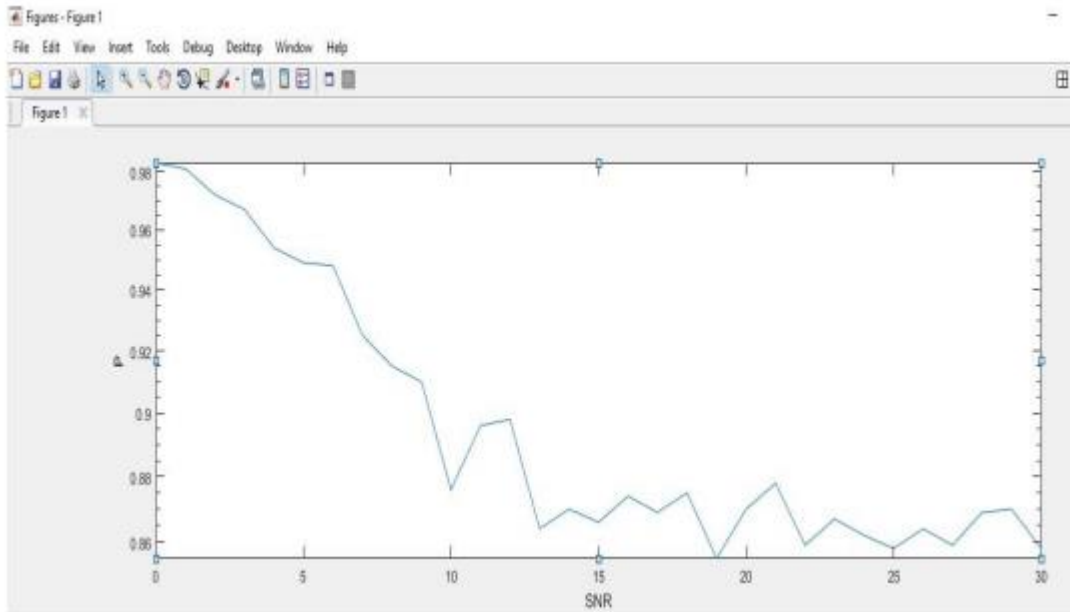

[CE 2.11] I analyzed the synchronization impact in a pairwise transmission which specifically dependent on multi-way wireless relay network mainly associated with the normal transmission, symbol misalignment, and phase offsets. I obtained higher error performance of the system in the normal transmission which led towards noting error probability of at least one error. I executed the graph which indicated that the probability initiated from 1 and it reduced all the way. The graph shows that the probability starts at 1. Thus, the error chances were low and there was a phase offer in the user's signal the performance of error was also low which led towards analyzing the probability of at least one error. It was then compared to the normal transmission and the graph showed the point from where it initially started which gradually reduced at a small rate. I researched the transmission with the symbol with no phase offset in the user signal. It led towards identifying the error probability which was higher as compared to the normal transmission. Thus, the performance of error was low and it provided a clear system model view which was of higher probability when there were symbol misalignment and phase offset. It even indicated the proper synchronization impact in the user signals and created higher error probability in the message of the user with inappropriate synchronization.

D) Summary

[CE 2.12] The associated work objectives were evaluated appropriately in the project and made thorough research regarding the multi-way relay networks. There was appropriate research made on various factors throughout the project and associated work results were accomplished within the set timeline with constant expertise applied in the electrical engineering field.

Career Episode 3

Development of Count System using RFID

A) Introduction

[CE 3.1]

Title: Development of Count System using RFID

Duration: [Date] – [Date]

Location: Deakin University, Australia

Position: Electrical Engineering Student

B) Background

[CE 3.2] The conceptual work is mainly for maintaining time management and carrying out proper scheduling activities. There is a requirement to implement an effective and low-cost automation system. In recent times, the systems mainly developed are based on counting purposes and manual systems. Thus, the GSM module mainly utilized for wireless network creation which is easier to utilize and available readily.

[CE 3.3] The project goal was developing a count system utilizing GSM and RFID technology. I selected RFID technology which was an emerging technology mainly utilized in various applications. I typically did object identification based on RFID technology and it mainly composed of RFID reader and RFID tag. I utilized RFID tags in the RFIS system mainly interrogated from the RFID reader. The work primary goal was based on the identification of data in an automatic manner that was contained in electromagnetic fields. I used the smaller and inexpensive RFID tags and these were for deriving power via RFID reader from the small-signal produced.

[CE 3.4] The work carried out with GSM technology utilization which worked with the short messaging service (SMS) for sending text messages to the remote receiver from the local transmitter. From the GSM standard evolution, the SMS worked as the feature for sending messages and it worked up to 40 kilobits per second.

[CE 3.5]

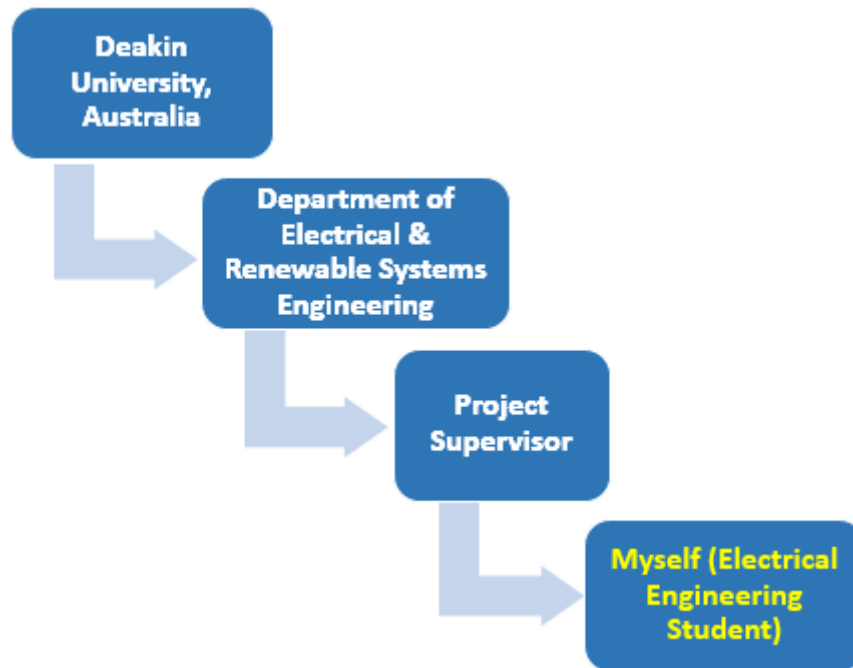

[CE 3.6] The related work duties were:

- I conducted research and used electrical engineering knowledge for RFID technology utilization which was an effective way for the identification of objects.
- I did system execution which was based on wireless control usage and it effectively assisted in system usage for unwired connections.
- I did RFID reader usage mainly based on RFID tag interrogation.
- I worked on setting an antenna with the reader for the emission of radio waves and tag responded well in sending the data back appropriately.

C) Personal Engineering Activity

[CE 3.7] I designed and developed a system for carrying out time management with cell phone utilization via a global system for GSM technology. I implemented cellular communication which worked as the potential solution for remote controlling activities. I utilized SMS (short message service) technology for reminding the schedule and RFID technology worked as an emerging technology utilized in various applications range. I used the RFID technology which was a fast and reliable way for object identification. I executed the system which utilized wireless control and was effectively utilized in the system for carrying out unwired connections. I made utilization of the system with the user's₁₂

Name: PROFESSIONAL CIVIL ENGINEER - QUANTITY SURVEYOR



AustraliaCDRHelp.Com
Competency Report Writing Helper

mobile handset for controlling and the system was cost-effective and adaptable with providing ubiquitous access towards application control. I made proposed system usage of wireless controlling which effectively worked in the system and the system utilized the user's mobile handset for the remainder along with RFID technology for finding objects. Thus, the system was more adaptable and cost-effective along with providing definite access for application control.

[CE 3.8] implemented the schematic block diagram for the system proposed as indicated in the below:

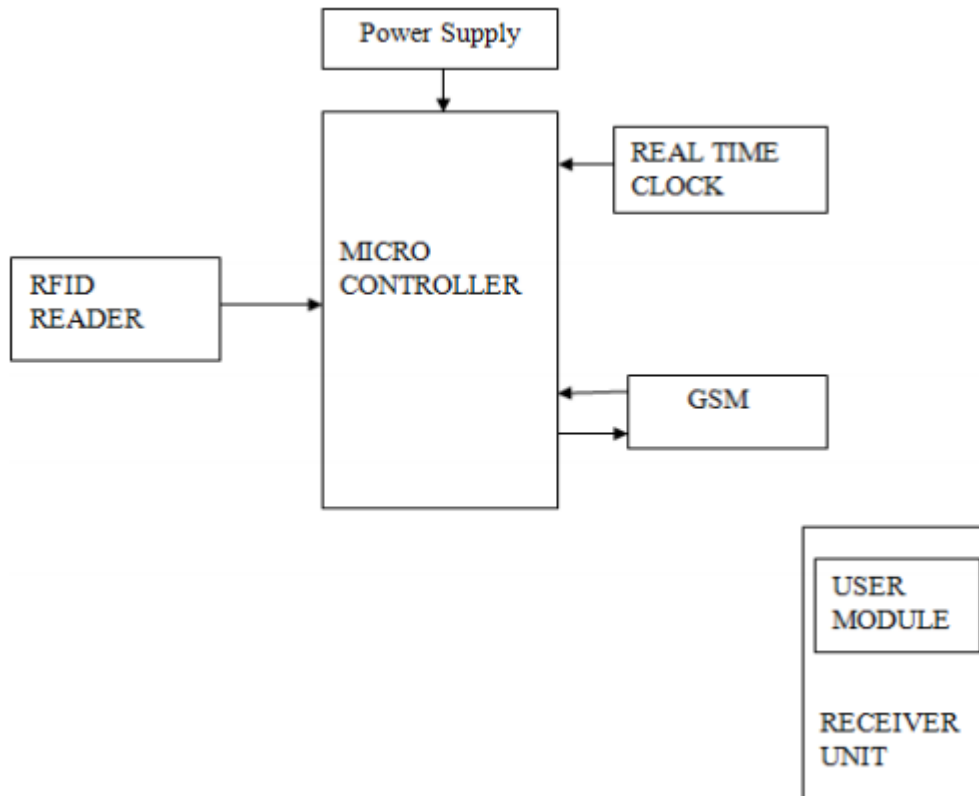

I utilized the controller for controlling the project in the system and utilized the SIM900 module which worked as the Short Messaging Servicing for sending text messages from the local transmitter to the remote receiver via AT command. I utilized RFID reader which was utilized for interrogation of an RFID tag. I used an antenna with the reader for radio waves emission and the tag responded in terms of sending the data back. I used RTC as the main device component which was for keeping appropriate time tracking.

[CE 3.9] analyzed the digital circuit which worked with low DC voltage and a power supply unit was needed for providing the appropriate supply of voltage. I used a rectifier, transformer, regulator, and a filter. I connected the AC voltage which was 230Vrms to a transformer for stepping the AC voltage down to the needed voltage level. I selected a diode rectifier that provided a full-wave rectified voltage mainly filtered from a simple capacitor for producing a DC voltage. It resulted in DC voltage ripples and regulator circuits were utilized with DC input for providing DC voltage and it remained in the same DC value even when the DC voltage varied. I obtained the needed DC supply from AC supply after filtration, regulation, and rectification. The power supply unit block diagram is below:

13

Name: PROFESSIONAL CIVIL ENGINEER - QUANTITY SURVEYOR

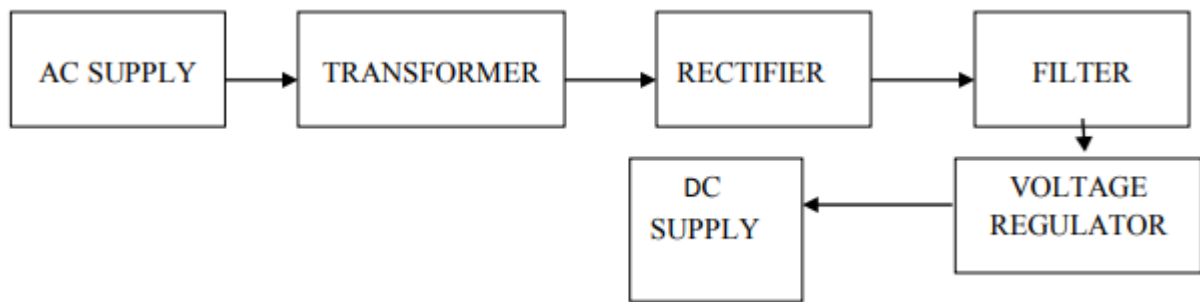

[CE 3.10]The implemented circuit diagram is below:

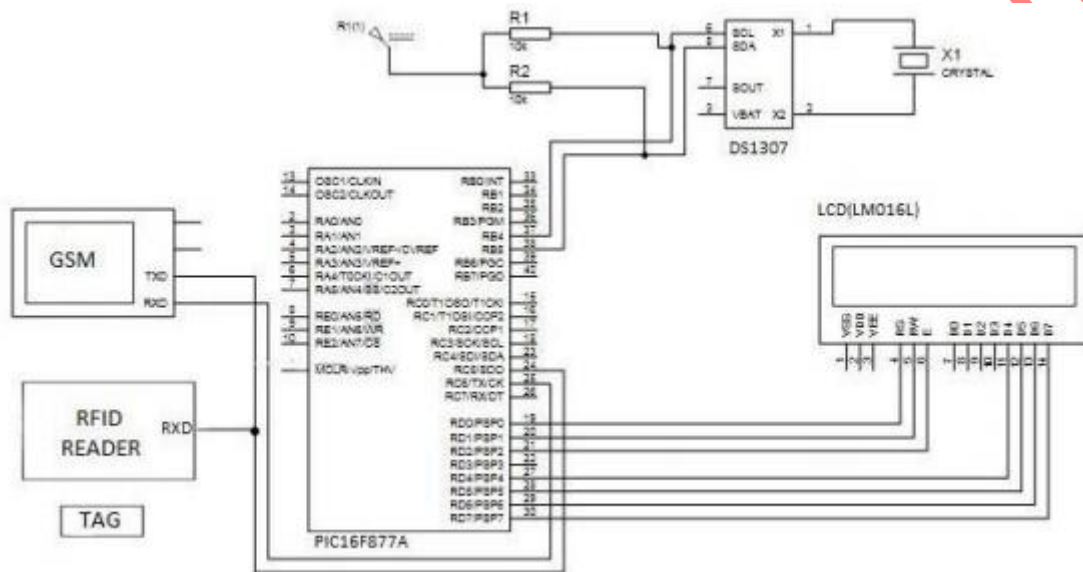

I developed the device mainly allowed for a user to maintain a schedule utilizing RFID technology and a cellular phone. It was for automatic data identification which was contained in electromagnetic fields. I executed the system which was a flexible and powerful tool mainly offered the service at a defined time with technologies constraints being considered. I utilized a phone for sending a text message and utilized the concept for system designing which acted as a platform for receiving messages mainly worked for sending commands for controlling various devices and appliances connected to the control system. It was linked with PICC and acted as the main controller. The control system designing was dependent on GSM technology effectively allowed remote areas controlling over the appliances which were linked with the microcontroller system. I immense the suggested system application in the altering technology where automation was the most effective way. It allowed freedom of higher degree to an individual member when sending commands to the controller. There was the requirement to be present physically for counting the person where entering in appropriate time was done with the system usage. I proposed the approach for system designing which was linked with microcontroller based control module implementation mainly for receiving the commands and instructions from the cellular phone over the GSM network mainly interfaced with the module of the microcontroller. I then carried out the microcontroller for issuing commands and the local interfacing method worked with the GSM technology utilization. I analyzed the existing devices such as RFID reader which received the data and controlling was done from the microcontroller. I utilized LCD for displaying

Name: PROFESSIONAL CIVIL ENGINEER - QUANTITY SURVEYOR

the status of the device using Electrical Engineering knowledge.

[CE 3.11] I did the evaluation and fabrication of a prototype system for SMS based time management system technology. It mainly scheduled for the education system and the microcontroller mainly fed with the electrical current for carrying out the operation. I used an ID tag for carrying out reading operations from RFID reader and the time was obtained from RTC which resulted in reading from the microcontroller with predefined command set assistance. It mainly provided by the user linked with the microcontroller. I used a microcontroller for command analysis and instructed the GSM module for sending a module to send an SMS to a specific person in the controller from predefined coding.

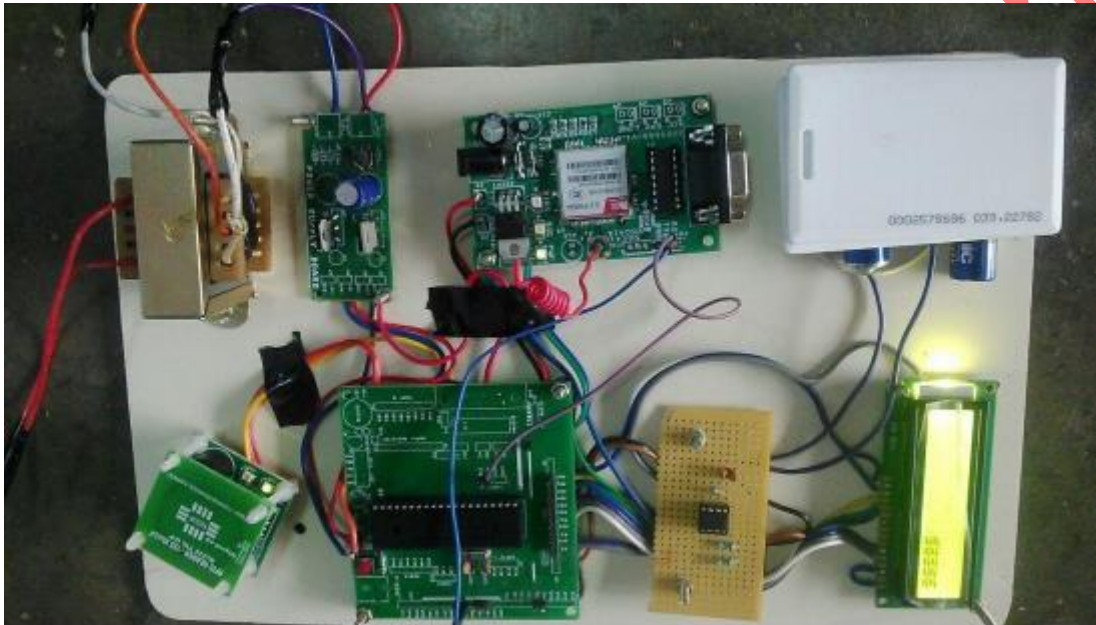

D) Summary

[CE 3.12] For a human generation, the concept of SMS based time management was advantageous due to the fact the communication via mobile is in trending in recent days. It resulted in keeping a human as perfect and also executed timekeeping. A mobile phone can utilize as a control system which was simple and cost-effective in a simple automation system where internet facilities were not provided. The work activities were split into several sections and electrical engineering skills were applied appropriately for getting the specified work results within the set project timeframe.

PROFESSIONAL ENGINEER Summary Statement

These are the competency Units and Elements. These elements must be addressed in the Summary Statement (see Section C). If you are applying for assessment as a Professional Engineer, you will need to download this page, complete it and lodge it with your application.

Competency Element	A brief summary of how you have applied the element	Paragraph number in the career episode(s) where the element is addressed
PE1 KNOWLEDGE AND SKILL BASE		
PE1.1 Comprehensive, theory-based understanding of the underpinning natural and physical sciences and the engineering fundamentals applicable to the engineering discipline	The appropriate research being made when carrying out three different projects in the electrical engineering domain.	CE 1.3, CE 2.1, CE 3.3
PE1.2 Conceptual understanding of the mathematics, numerical analysis, statistics and computer and information sciences which underpin the engineering discipline	I did adequate execution of conceptual engineering objectives which were needed for appropriate completion of work activities and these were attained using electrical engineering skills.	CE 1.4, CE 2.7, CE 3.6
PE1.3 In-depth understanding of specialist bodies of knowledge within the engineering discipline	I made thorough research related to various electrical engineering concepts and accomplished the work results within the set work timeline.	CE 1.8, CE 2.10, CE 3.9
PE1.4 Discernment of knowledge development and research directions within the engineering discipline	I conducted appropriate research related to electrical engineering principles when implementing the work activities and achieved the desired results accordingly.	CE 1.9, CE 2.11, CE 3.10
PE1.5 Knowledge of contextual factors impacting the engineering discipline	I conducted conceptual research related to numerous work factors and accomplished the work results within the provided project timeframe.	CE 1.12, CE 2.8, CE 3.11
PE1.6 Understanding of the scope, principles, norms, accountabilities and bounds of contemporary engineering practice in the specific discipline	I applied decent electrical engineering skills and contemporary engineering practices were maintained in the entire work tenure.	CE 1.10, CE 2.9, CE 3.7
PE2 ENGINEERING APPLICATION ABILITY		
PE2.1 Application of established engineering methods to complex engineering problem solving	I carried out electrical engineering conceptual skills utilization in the work and attained the results within the provided project timeframe.	CE 1.8, CE 2.10, CE 3.7
PE2.2 Fluent application of engineering techniques, tools and resources	I did fluent engineering concepts usage and accomplished the work results within the provided project timeframe and it assisted well in getting all the required work results.	CE 1.12, CE 2.9, CE 3.8
PE2.3 Application of systematic engineering synthesis and design processes	I applied appropriate engineering principles utilization with the systematic conduct maintained adequately in the provided project timeframe.	CE 1.10, CE 2.11, CE 3.10
PE2.4 Application of systematic approaches to the conduct and management of engineering projects	I researched on various work factors and achieved the project results with engineering management principles applied appropriate in the project defined timeline.	CE 1.8, CE 2.9, CE 3.6
PE3 PROFESSIONAL AND PERSONAL ATTRIBUTES		

Name: PROFESSIONAL CIVIL ENGINEER - QUANTITY SURVEYOR



AustraliaCDRHelp.Com
Competency Report Writing Helper

PE3.1 Ethical conduct and professional accountability	There was ethical attitude maintained in the work with professional accountability considered when implementing the technical activities.	CE 1.10, CE 2.10, CE 3.9
PE3.2 Effective oral and written communication in professional and lay domains	I did effective implementation of oral and written communication skills for getting the timely results.	CE 1.11, CE 2.12, CE 3.10
PE3.3 Creative innovative and proactive demeanour	I executed creative principles utilization and accomplished the work results using electrical engineering skills.	CE 1.12, CE 2.9, CE 3.8
PE3.4 Professional use and management of information	I did professional skills utilization when implementing the technical activities and obtaining the results using electrical engineering skills.	CE 1.7, CE 2.10, CE 3.7
PE3.5 Orderly management of self, and professional conduct	I executed the systematic conduct in the work and achieved the results using electrical engineering skills.	CE 1.9, CE 2.8, CE 3.11
PE3.6 Effective team membership and team leadership	I executed the work activities under the leadership of project supervisor and obtained the results.	CE 1.11, CE 2.12, CE 3.10

AustraliaCDRhelp.com

Name: PROFESSIONAL CIVIL ENGINEER - QUANTITY SURVEYOR

